

BPW Transpec answers to PBS vehicles and improved roll stability

BPW Transpec has released a third new spring trailing arm for AL2 air suspensions with an improved roll stiffness rating. The new spring trailing arm is 65mm thick rather than the original 62mm thickness. The increased thickness improves roll stiffness by at least 25%.

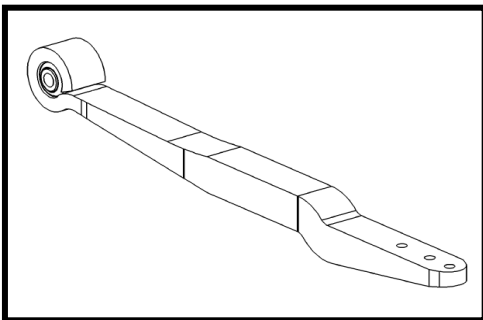

05.082.14.43.2 (AO)

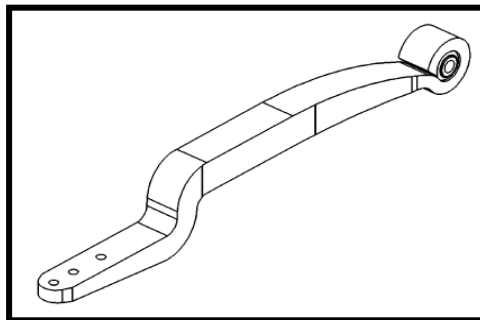

05.082.14.44.2 (AM)

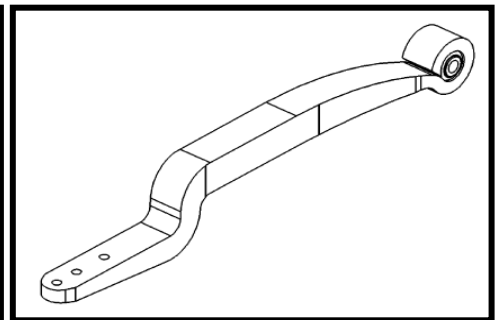

05.082.14.34.2 (AO/AU)

Original Spring (62mm Thickness)	Replacement Spring (65mm Thickness)	Use
05.082.13.95.2	05.082.14.44.2	Already Standard in Australia
05.082.13.96.2	05.082.14.43.2	Available
05.082.14.02.2	05.082.14.34.2	Available Jan 2024

When replacing the Original 62mm Spring with the new 65mm Spring, both left hand and right hand Springs need to be changed to ensure even stability.

These springs are available in the most common BPW suspension models currently available and can be substituted with no dimensional changes for the trailer builder.

Talk to our sales consultants or engineering team about solutions for your vehicle: -

- Higher rated spring trailing arms
- Adding stabilizer bars
- Wide track axles and single tyre applications

Victoria (Head Office)

1-11 Cherry Lane,
Laverton North Vic 3026
Phone (03) 9267 2444
Fax (03) 9369 4826

New South Wales

10 Squill Place,
Arndell Park NSW 2148
Phone (02) 8811 7000
Fax (02) 8811 7050

Queensland

10 Bernoulli Street,
Darra Qld 4076
Phone (07) 3217 0877
Fax (07) 3217 0230

Western Australia

1021 Abernethy Road,
High Wycombe WA 6057
Phone (08) 9454 4000
Fax (08) 9454 4111

info@bpwtranspec.com.au
bpwtranspec.com.au